



CHICKEN COOP BUILDING REQUIREMENTS

Chicken coops are defined by the City of West Bend Zoning Code section 17.44. Construction of a chicken coop follow the same requirements of the State of Wisconsin Uniform Dwelling Code. (SPS320-325) This code is available online at: <http://dsps.wi.gov/sb/SB-DivCodesListing.html>.

The maximum size of an accessory building for properties zoned residential is 720 square feet. If there are several out buildings on the parcel, the total may not exceed 720 square feet. The principal use of the property where a chicken coop and yards may be permitted is limited to single-family dwellings and duplexes within single-family or two-family zoned property. The chicken coop must be water-proof, rodent-proof, predator-proof and enclosed in a fenced-in area.

Chicken coops must be placed in the rear yard and have a minimum setback of 5 feet from the lot line. No coop or run shall be placed within 25 feet of any separate residential or business structure on an adjacent lot. Lot markers and property lot lines must be visible at the time of inspection. The maximum height is 18 feet. Enclosures for chicken runs may be comprised of welded wire or chicken wire material but not be part of a residential fence within the property.

In order to obtain your permit you must provide a plat of survey showing the lot lines and proposed/existing buildings on the property in relation to each other. An accessory structure may not be constructed in an easement. It shall be the owner's responsibility to verify that keeping chickens and chicken coops are permitted uses in any deed restrictions or covenants applicable to the subject property.

If you have any questions please call (262) 335-5140 between 8:00am and 4:30pm Monday through Friday before proceeding.

Submit the following to Building Inspection for Review and Processing:

- Plat of survey showing property lines, easements, existing buildings, & the coop and fence proposed locations.
- 2 sets complete plans of coop & detail of fencing for run
- Completed Permit Applications
- Building Inspection Fees: \$ 0.35 per sq. ft. Building Permit
\$25.00 Plan Review
\$75.00 Zoning Permit >100sq.ft.
- Finance Department Fee: \$50.00 Annual License

NO CHICKENS WILL BE ALLOWED IN COOPS UNTIL FINAL INSPECTION

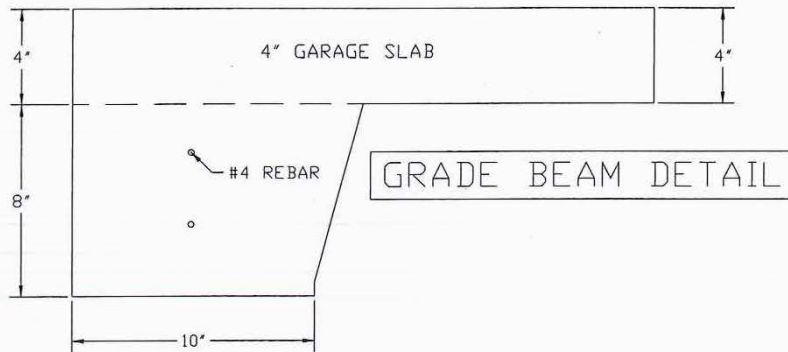

Anchor Detail

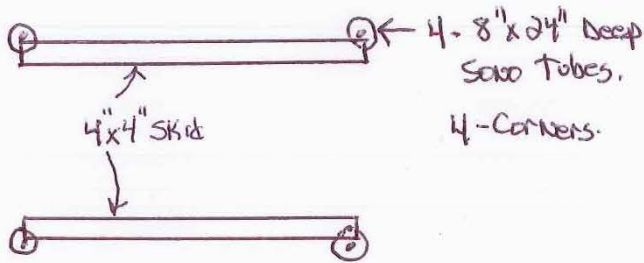

Earth Anchor Detail.

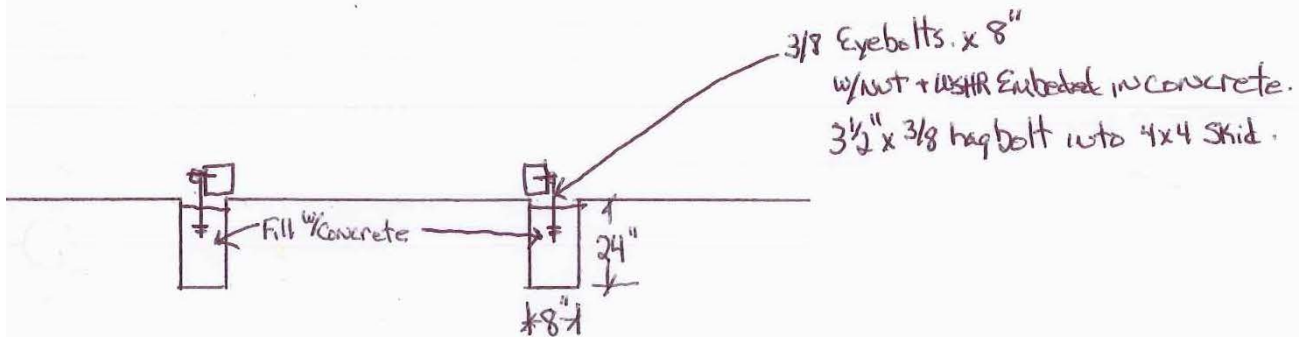
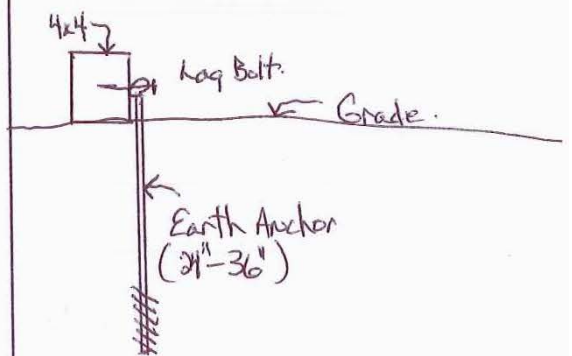

ORDINANCE 2823
2018-2019 COMMON COUNCIL

Discussion on Amending Section 9.07 and Creating Section 9.075 and 12.175 of the Municipal
Code Regarding Keeping of Chickens in the City

The Common Council of the City of West Bend do ordain as follows:

SECTION ONE. Section 9.07 is amended to read as follows:

9.07 ANIMALS OR SPECIES PROHIBITED WITHIN THE CITY.

(1) Keeping of Fowl Prohibited. Except as provided in Section 9.075, no person shall keep, raise or have in his possession any live fowl within the City, erect or maintain and use on any lot or parcel of land within the City any run , coop, structure or other building for the purpose of keeping or housing any type of fowl, including, but not limited to, chickens, geese, ducks, turkeys, pheasants or guinea hens, except, however, the keeping of racing or show pigeons.

SECTION TWO. Section 9.075 is created to read as follows:

Section 9.075 KEEPING OF CHICKENS.

(a) No person shall keep or harbor any chickens or build, erect or maintain and use any chicken coop or run within the City without registering the name and address of the owner, the number of chickens, and paying the requisite license fee pursuant to Section 12.175.

(b) Chickens must be contained within a coop or enclosed chicken run and may not be allowed to roam at large within or beyond the property.

(c) Prior to issuance of a site license for the keeping of chickens, the owners of adjoining and surrounding properties shall be notified by the City Treasurer of the pending license request.

(d) All chicken coops and runs wherein any chickens are contained shall be kept in a clean, sanitary condition and free from all objectionable odor or vermin.

(e) Chicken coops and runs under this section shall be limited to the keeping of up to a total of four chickens per property, and shall be subject to the following conditions:

1. The principal use of the property where a chicken coop and yards may be permitted is limited to single-family dwellings and duplexes within single-

- family or two-family zoned property.
2. No person shall keep any rooster.
 3. No person shall slaughter any chickens.
 4. Chickens shall be kept in a water-proof, rodent-proof and predator-proof coop in a fenced-in area.
 5. Coops shall be considered accessory structures under Chapter 17 and shall be subject to all requirements of that Chapter. Coops and runs shall be placed in rear yards and shall have a minimum setback of 5 feet. No coop or run shall be placed within 25 feet of any separate residential or business structure on an adjacent lot.
 6. Enclosures for chicken runs maybe comprised of welded wire or chicken wire material but may not be part of a residential fence within the property.
 7. It shall be property owner's responsibility to verify that keeping chickens and chicken coops are permitted uses in any deed restrictions or covenants applicable to the subject property.

SECTION THREE. Section 12.175 is created to read as follows:

(a) LICENSE REQUIRED. It shall be unlawful for any person in the City to own, harbor or keep chickens without complying with the provisions of this Section and Section 9.075.

(b) LICENSE FEES. The yearly license fee for chickens shall be \$50 per site license

(c) LATE FEES. The City Treasurer shall assess and collect a late fee of \$5 from every owner of a chicken if the owner failed to obtain a license prior to April 1 of each year or prior to acquiring ownership of a chicken.

Passed and Approved the 21st day of January, 2019

Introduced by Alderperson _____
Chris Jenkins

Kraig K. Sadownikow, Mayor

Attest: _____
Stephanie Justmann, City Clerk

Approved as to legality: _____
Ian Prust, City Attorney

Published the 26th day of January, 2019.



Building Permit Application
 1115 S. Main Street
 West Bend, WI 53095
 Phone 262.335.5140 Fax 262.335.5182
 inspect@ci.west-bend.wi.us

Address of Project:

Permit #:

MUNICIPALITY: (check one) **CITY OF WEST BEND** **VILLAGE OF KEWASKUM**

Description of Project:

Total Cost of Project: \$ _____ **Cost w/o Mechanicals: \$** _____ **Cost w/o Lot: \$** _____

Building Type: Single Family 2-Family Multifamily Commercial

Owner Information:

Name: _____

Address: _____

Day Phone # _____

Evening Phone # _____

Contractors: (List All That Apply)

Building Contractor:

Phone # _____

Address: _____

Dwelling/Building Contractor # _____

Dwelling Qualifier # _____

Contact Person: _____

Electrical Contractor:

Phone # _____

Address: _____

Electrical Contractor # _____

Master License # _____

Contact Person: _____

HVAC Contractor:

Phone # _____

Address: _____

HVAC Contractor Cert # _____

Contact Person: _____

Plumbing Contractor:

Phone # _____

Address: _____

Master Plumber Cert # _____

Contact Person: _____

Permit Fees:

Building	_____	Sq. Ft. x .35 =	_____
Plumbing	_____	Sq. Ft. x .06 =	_____
Gas Piping	_____	Sq. Ft. x .06 =	_____
HVAC	_____	Sq. Ft. x .06 =	_____
Electrical	_____	Sq. Ft. x .06 =	_____
Water Service	_____	L/F x .60 =	_____
Sanitary Sewer	_____	L/F x .60 =	_____
Storm Sewer	_____	L/F x .60 =	_____
Occupancy Permit		\$60/Unit	_____ Units = _____
Commercial Occ.		\$200.	_____
State Seal		\$40.00	_____
Erosion Control		\$200.00	_____
Zoning		\$75.00	_____
Razing	\$100. Minimum plus	.09 Sq. Ft. \$300 Maximum	Sq. Ft. = _____
Moving	\$100. Minimum plus	.09 Sq. Ft.	Sq. Ft. = _____
Footing & Foundation (Early Start)		\$200.00	_____
Plan Review	1 & 2 Family	\$200.00	_____
Plan Review	Commercial	State Fee	_____
Plan Review	Miscellaneous	\$25.00	_____
Minimum Permit Fee		\$35.00	_____

PAID BY: _____ **CHECK #:** _____ **TOTAL FEE** _____

It is hereby agreed between the undersigned and the City of West Bend that all work performed as herein described, according to the plans and specifications herewith presented, shall be completed in strict compliance with the ordinances of the City of West Bend and all laws of the State of Wisconsin. By signing this permit application, it is understood that a contract exists between the owner and the City of West Bend and guarantees the right to enter for required inspections and investigations. Applicant is obligated to ensure final inspection is made.

CAUTIONARY STATEMENT TO OWNER OBTAINING BUILDING PERMITS

101.65(lr) of the Wisconsin Statutes requires municipalities that enforce the Uniform Dwelling Code to provide an owner who applies for a building permit with a statement advising the owner that:

If the owner hires a contractor to perform work under the building permit and the contractor is not bonded or insured as required under s.101.654(2) (a), the following consequences might occur:

- (a) The owner may be held liable for any bodily injury to or death of others or for any damage to the property of others that arises out of the work performed under the building permit or that is caused by an negligence of the contractor that occurs in connection with the work performed under the building permit.
- (b) The owner may not be able to collect from the contractor damages for any loss sustained by the owner because of a violation by the contractor of the one and 2 family dwelling code or an ordinance enacted under sub.(1)(a), because of any bodily injury to or death of others or damage to the property of others that arises out of the work performed under the building permit or because of any bodily injury to or death of others or damage to the property of others that is caused by any negligence by the contractor that occurs in connection with the work performed under the building permit.

INITIALS _____

Signature of Applicant: _____

Date: _____

City of West Bend Approval: _____

Date: _____



1115 S Main St
West Bend WI 53095
(262)335-5118

CHICKEN LICENSE APPLICATION

Section 9.075/12.175 of City of West Bend Municipal Code

LICENSE FEE: \$50.00 PER SITE
4 CHICKEN LIMIT PER PROPERTY/NO ROOSTERS

****\$5.00 late renewal fee applies after March 31st**
****Licenses are issued for one calendar year regardless of issuance date.**

Date Issued	
Number of Chickens	
Amount Paid	
Payment Method	
License Number	

Applicant Name: _____
(Please Print)

Address: _____

Telephone (daytime): _____ Cell Number: _____

E-mail Address: _____

Section 9.075 Keeping of Chickens

- No person shall keep or harbor any chickens or build, erect or maintain and use any chicken coop or run within the City without registering the name and address of the owner, the number of chickens, and paying the requisite license fee pursuant to Section 12.175.
- Chickens must be contained within a coop or enclosed chicken run and may not be allowed to roam at large within or beyond the property.
- Prior to issuance of a site license for the keeping of chickens, the owners of adjoining and surrounding properties shall be notified by the City Treasurer of the pending license request.
- All chicken coops and runs wherein any chickens are contained shall be kept in a clean, sanitary condition and free from all objectionable odor or vermin.
- Chicken coops and runs under this section shall be limited to the keeping of **up to a total of four chickens per property**, and shall be subject to the following conditions:
 - (1) Limited to single-family dwellings and duplexes within single family or two-family zoned property.
 - (2) No Roosters
 - (3) No person shall slaughter any chickens.
 - (4) Chickens shall be kept in a water-proof, rodent-proof and predator-proof coop in a fenced-in area.
 - (5) Coops shall be considered accessory structures under Chapter 17 and shall be subject to all requirements of that Chapter. Coops and runs shall be placed in rear yards and shall have a minimum setback of 5 feet. No coop or run shall be placed within 25 feet of any separate residential or business structure on an adjacent lot.
 - (6) Enclosures for chicken runs may be comprised of welded wire or chicken wire material but may not be part of a residential fence within the property.
 - (7) It shall be the property owner's responsibility to verify that keeping chickens and chicken coops are permitted uses in any deed restrictions or covenants applicable to the subject property.

Noncompliance of Sections 9.075/12.175 could result in a citation.

DEPT OF BUILDING INSPECTIONS: _____
Authorized Signature

OWNER SIGNATURE: _____