

EFFECTIVE:
02-OCT-12

HORIZONTAL MOTORS

PRINT:
07-3016

SUPERSEDES:
18-JUL-12

FRAME: 400TS
BASIC TYPE: CE

SHEET:
1 OF 1

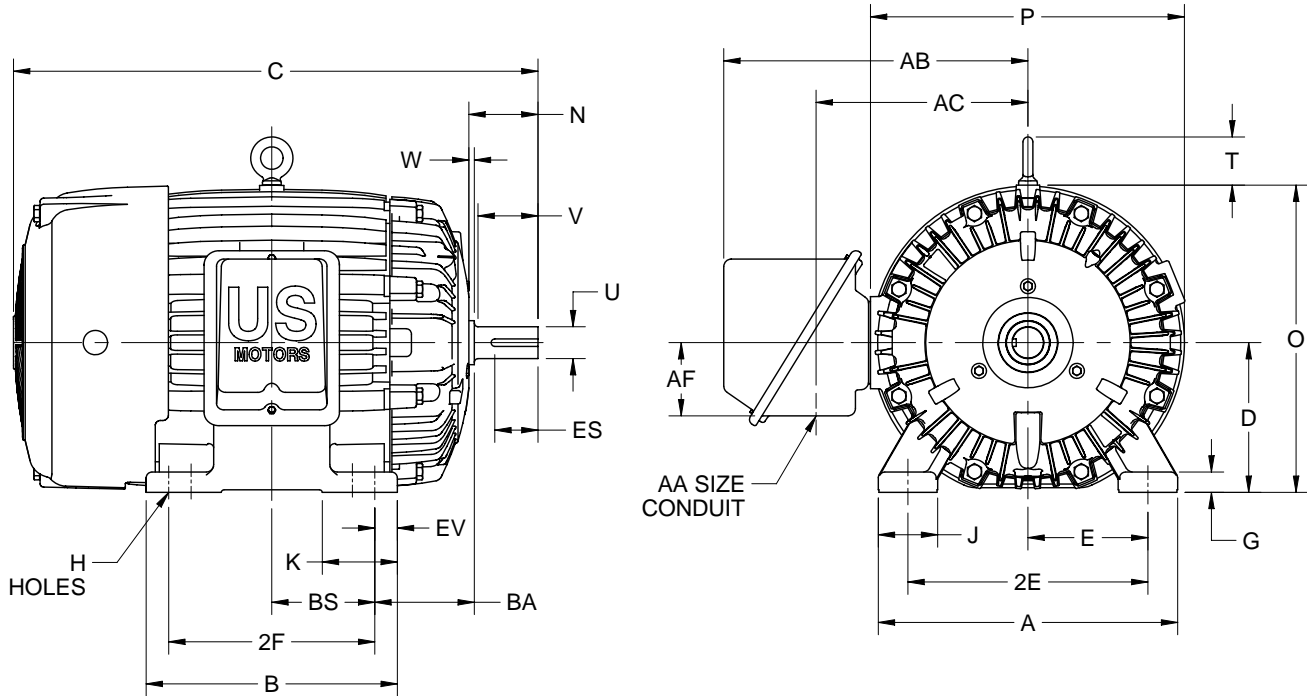

ALL DIMENSIONS ARE IN INCHES AND MILLIMETERS

	A	B	C	D -.06	E	2E ±.03	G	H +.05	J
IN	19.75	16.75	35.00	10.00	8.00	16.00	1.38	.81	3.75
MM	502	425	889	254	203	406	35	21	95

	K	N	O	P ²	T	U -.001	V MIN	W	AA
IN	5.00	4.38	20.50	20.94	3.22	2.125	4.00	.13	3 NPT
MM	127	111	521	532	82	53.98	102	3	

	AB	AC	AF	BA	BS	ES MIN	EV	SQ KEY
IN	20.28	14.13	4.88	6.63	6.88	2.78	1.50	.500
MM	515	359	124	168	175	71	38	12.70

	FRAME	2F ±.03
IN	404TS	12.25
MM		311
IN	405TS	13.75
MM		349

1. DIMENSIONS MAY VARY .25" DUE TO CASTING AND/OR FABRICATION VARIATIONS.
2. LARGEST MOTOR WIDTH
3. TOLERANCES ARE SHOWN IN INCHES.
4. CONDUIT BOX MAY BE LOCATED ON EITHER SIDE OF MOTOR. CONDUIT OPENINGS MAY BE LOCATED IN STEPS OF 90 DEGREES REGARDLESS OF LOCATION. STANDARD AS SHOWN WITH CONDUIT OPENING DOWN.

07-3016/A

Nidec Motor Corporation
St. Louis, Missouri

INFORMATION DISCLOSED ON THIS DOCUMENT IS CONSIDERED PROPRIETARY AND SHALL NOT BE REPRODUCED OR DISCLOSED WITHOUT WRITTEN CONSENT OF NIDEC MOTOR CORPORATION



ISSUED BY
K. FRIEDMAN
APPROVED BY
J. O'BRIEN

IHP_DP_NMCA (MAR-2011) SOLIDEDGE