

EFFECTIVE:
08-MAR-11

HORIZONTAL MOTORS WITH NEMA "C" BRACKET

PRINT:
07-2546

SUPERSEDES:
15-JAN-03

FRAME: 140TC
BASIC TYPE: CE

SHEET:
1 OF 1

F-2 ASSEMBLY

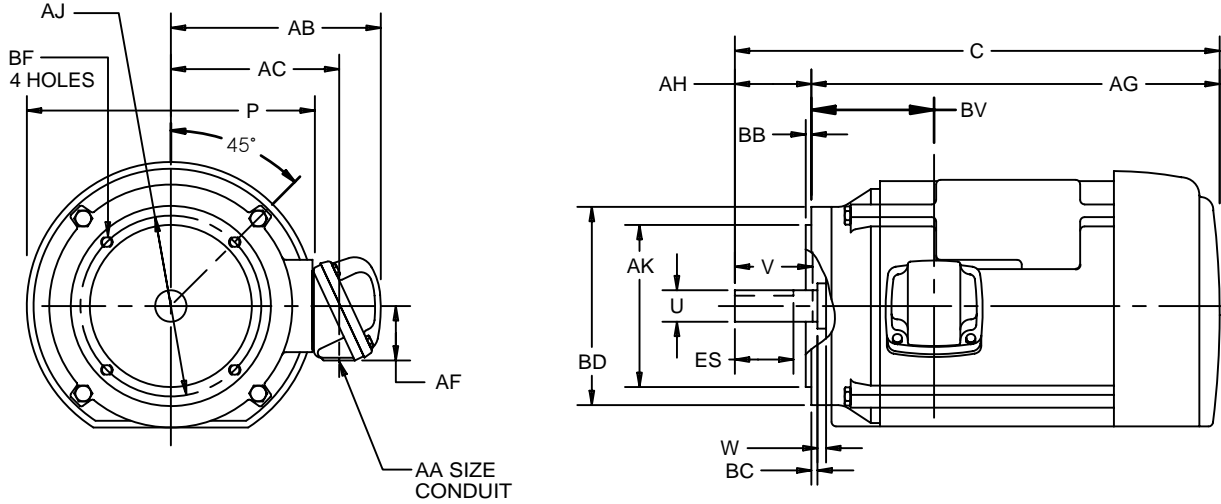

ALL DIMENSIONS ARE IN INCHES AND MILLIMETERS

UNITS	C	P ⁵	U -.0005	V MIN	W	AA	AB	AC	AF	AG	AH	AJ	AK -.003
IN	13.50	8.00	.8750	2.06	.19	3/4 NPT	7.38	5.06	2.13	11.38	2.13	5.875	4.500
MM	343	203	22.225	52	5		187	129	54	289	54	149.23	114.30

UNITS	BB -.060	BC	BD	BF ²	BV	ES MIN	SQ KEY
IN	.16	.13	6.50	3/8-16 x .56	3.56	1.41	.188
MM	4	3	165		90	36	4.78

TOLERANCES	
FACE RUNOUT	.004 T.I.R.
PERMISSIBLE ECCENTRICITY OF MOUNTING RABBET	.004 T.I.R.
PERMISSIBLE SHAFT RUNOUT	.002 T.I.R.

- 1: ALL ROUGH DIMENSIONS MAY VARY BY .25" (6mm) DUE TO CASTING AND OR FABRICATION VARIATIONS.
- 2: TAP SIZE AND BOLT PENETRATION ALLOWANCE.
- 3: ALL TAPPED HOLES ARE UNIFIED NATIONAL COARSE, RIGHT HAND THREAD.

- 4: CONDUIT BOX MAY BE LOCATED ON EITHER SIDE OF MOTOR. CONDUIT OPENINGS MAY BE LOCATED IN STEPS OF 90 DEGREES REGARDLESS OF LOCATION. STANDARD AS SHOWN WITH CONDUIT OPENING DOWN.
- 5: LARGEST MOTOR WIDTH.
- 6: ALL TOLERANCES ARE IN INCHES ONLY.

07-2546/A

Nidec Motor Corporation
St. Louis, Missouri

INFORMATION DISCLOSED ON THIS DOCUMENT IS CONSIDERED PROPRIETARY AND SHALL NOT BE REPRODUCED OR DISCLOSED WITHOUT WRITTEN CONSENT OF NIDEC MOTOR CORPORATION



ISSUED BY
R. KING
APPROVED BY
K. POTTER

IHP_DP_NMCA (MAR-2011) SOLIDEDGE