

**NIDEC MOTOR CORPORATION**

8050 WEST FLORISSANT AVE.  
ST. LOUIS, MO 63136



**DATE:** 2/11/2015

**P.O. NO.:** BH48  
**Order/Line NO.:** 17332 MN 100

**TO:**

**Model Number:** BH48  
**Catalog Number:** 8P1P3C  
841 Plus Configuration  
CONF,MOTOR,841 PLUS

**REVISIONS:**  
(NONE)

**ALL DOCUMENTS HEREIN ARE CONSIDERED CERTIFIED BY NIDEC MOTOR CORPORATION.  
THANK YOU FOR YOUR ORDER AND THE OPPORTUNITY TO SERVE YOU.**

**Features:**

Horsepower ..... 00001.00 ~ KW: .746  
Enclosure ..... TEFC  
Poles ..... 06 ~ RPM: 1200  
Frame Size ..... 145~T  
Phase/Frequency/Voltage.. 3~060~460 ~ Random Wound  
Service Factor ..... 1.15  
Insulation Class ..... Class "F" ~ Insulife 2000  
Altitude In Feet (Max) .. 3300 Ft.(1000 M)  
Ambient In Degree C (Max) +40 C  
Assembly Position ..... "F-1" Assembly Position  
Efficiency Class ..... Premium Efficiency  
Application ..... Unknown  
Customer Part Number ....  
"AK" Dimension (Inches).. NA  
Temperature Rise (Sine Wave): "B" Rise @ 1.0 SF (Resist)  
Starting Method ..... Direct-On-Line Start  
Duty Cycle ..... Continuous Duty  
Efficiency Value ..... 80.0 % ~ NEMA Nominal  
Load Inertia (lb-ft<sup>2</sup>): NEMA ~ NEMA Inertia: 15.40 ~ 1.00  
Number Of Starts Per Hour: NEMA  
Motor Type Code ..... CE  
Rotor Inertia (LB-FT<sup>2</sup>) .113 LB-FT<sup>2</sup>  
Qty. of Bearings PE (Shaft) 1  
Qty. of Bearings SE (OPP) 1  
Bearing Number PE (Shaft) 25BC02JPP3  
Bearing Number SE (OPP) 25BC02JPP3

Nidec trademarks followed by the ® symbol are registered with the U.S. Patent and Trademark Office.

**NIDEC MOTOR CORPORATION**

8050 WEST FLORISSANT AVE.  
ST. LOUIS, MO 63136



**DATE:** 2/11/2015

**P.O. NO.:** BH48  
**Order/Line NO.:** 17332 MN 100

**TO:**

**Model Number:** BH48  
**Catalog Number:** 8P1P3C  
841 Plus Configuration  
CONF,MOTOR,841 PLUS

**REVISIONS:**  
(NONE)

**ALL DOCUMENTS HEREIN ARE CONSIDERED CERTIFIED BY NIDEC MOTOR CORPORATION.  
THANK YOU FOR YOUR ORDER AND THE OPPORTUNITY TO SERVE YOU.**

**Accessories:**

Corro-Duty  
Ground Lug In Conduit Box  
Precision Balance  
Standard Leadtime: REFER TO OFFICE  
Est. Weight (lbs ea): 70 ~ F.O.B.: St. Louis, MO  
Horsepower ..... 00001.00 ~ KW: .746  
Enclosure ..... TEFC  
Poles ..... 06 ~ RPM: 1200  
Frame Size ..... 145~T  
Phase/Frequency/Voltage.. 3~060~460 ~ Random Wound  
Service Factor ..... 1.15  
Insulation Class ..... Class "F" ~ Insulife 2000  
Altitude In Feet (Max) .. 3300 Ft.(1000 M)  
Ambient In Degree C (Max) +40 C  
Assembly Position ..... "F-1" Assembly Position  
Efficiency Class ..... Premium Efficiency  
Application ..... Unknown  
Customer Part Number ....  
"AK" Dimension (Inches).. NA  
Temperature Rise (Sine Wave): "B" Rise @ 1.0 SF (Resist)  
Starting Method ..... Direct-On-Line Start  
Duty Cycle ..... Continuous Duty  
Efficiency Value ..... 80.0 % ~ NEMA Nominal  
Load Inertia (lb-ft2): NEMA ~ NEMA Inertia: 15.40 ~ 1.00  
Number Of Starts Per Hour: NEMA  
Motor Type Code ..... CE  
Corro-Duty  
Ground Lug In Conduit Box  
Precision Balance  
Standard Leadtime: REFER TO OFFICE  
Est. Weight (lbs ea): 70 ~ F.O.B.: St. Louis, MO

**USE THE DATA PROVIDED BELOW TO SELECT THE APPROPRIATE DIMENSION PRINT**

**Horsepower** 1  
**Pole(s)** 06  
**Voltage(s)** 460  
**Frame Size** 145T  
**Shaft U Diameter** 0.875  
**Outlet Box AF** 2.13  
**Outlet Box AA** 0.75

Nidec trademarks followed by the ® symbol are registered with the U.S. Patent and Trademark Office.

EFFECTIVE:  
**13-APR-11**

# HORIZONTAL MOTORS

PRINT:  
**07-2106**

SUPERSEDES:  
**20-AUG-03**

FRAME: 143, 145T  
BASIC TYPE: CE

SHEET:  
**1 OF 1**

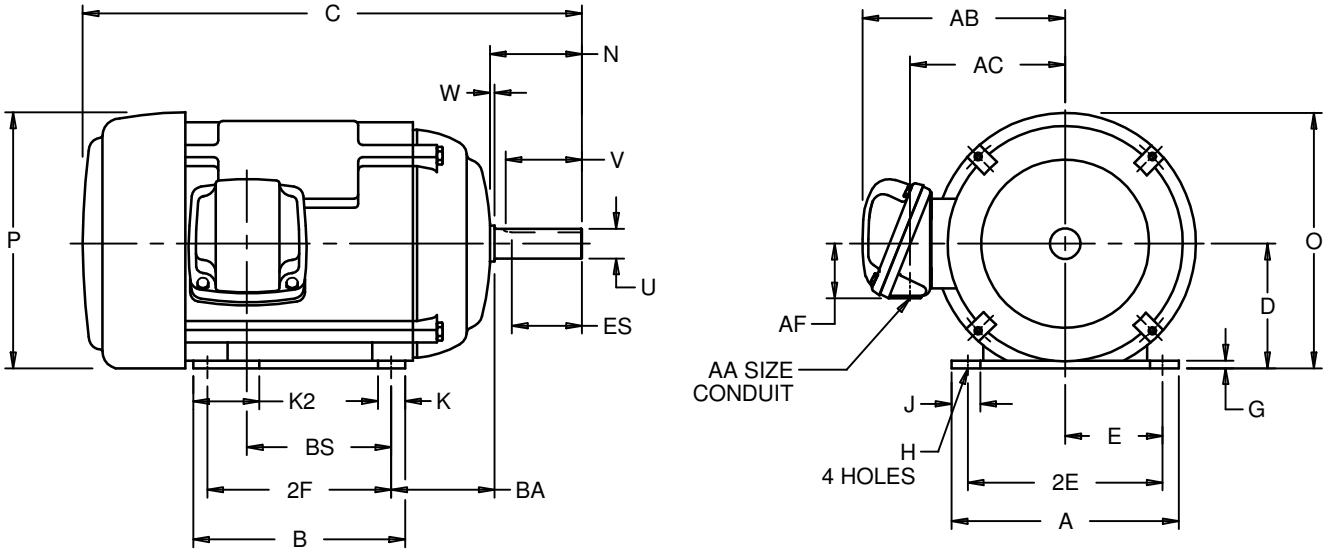

ALL DIMENSIONS ARE IN INCHES AND MILLIMETERS

UNITS	A	B	C	D -.06	E	2E ±.03	G	H +.05	J
IN	6.50	6.00	13.06	3.50	2.75	5.50	.16	.34	.94
MM	165	152	332	89	70	140	4	9	24

UNITS	K	K2	N	O	P <sup>2</sup>	U -.0005	V MIN	W	AA
IN	.94	1.94	2.38	7.50	8.00	.8750	2.06	.13	3/4 NPT
MM	24	49	60	191	203	22.225	52	3	

UNITS	AB	AC	AF	BA	BS	ES MIN	SQ KEY
IN	7.38	5.06	2.13	2.25	3.94	1.41	.188
MM	187	129	54	57	100	36	4.78

FRAME	UNITS	2F ±.03
143T	IN	4.00
	MM	102
145T	IN	5.00
	MM	127

1. ALL ROUGH DIMENSIONS MAY VARY BY .25" DUE TO CASTING AND/OR FABRICATION VARIATIONS.
2. LARGEST MOTOR WIDTH.
3. CONDUIT BOX MAY BE LOCATED ON EITHER SIDE. CONDUIT OPENINGS MAY BE LOCATED IN STEPS OF 90 DEGREES REGARDLESS OF LOCATION. STANDARD AS SHOWN WITH CONDUIT OPENING DOWN.
4. TOLERANCES SHOWN ARE IN INCHES ONLY.

07-2106/C

**Nidec Motor Corporation**  
St. Louis, Missouri

INFORMATION DISCLOSED ON THIS DOCUMENT  
IS CONSIDERED PROPRIETARY AND SHALL NOT BE  
REPRODUCED OR DISCLOSED WITHOUT WRITTEN  
CONSENT OF NIDEC MOTOR CORPORATION



ISSUED BY  
**R. PATIL**  
APPROVED BY  
**R. KING**

IHP\_DP\_NMCA (MAR-2011) SOLIDEDGE

# NAMEPLATE DATA

CATALOG NUMBER: <input style="width: 150px;" type="text" value="8P1P3C"/>		NAMEPLATE PART #: <input style="width: 150px;" type="text" value="422696-002"/>	
MODEL: <input style="width: 60px;" type="text" value="BH48"/> <input style="width: 60px;" type="text" value="FR"/> <input style="width: 60px;" type="text" value="145T"/>	TYPE: <input style="width: 60px;" type="text" value="CE"/> <input style="width: 60px;" type="text" value="ENCL"/> <input style="width: 60px;" type="text" value="TEFC"/>		
SHAFT END BRG: <input style="width: 150px;" type="text" value="25BC02JPP3 - QTY 1"/>		OPP END BRG: <input style="width: 150px;" type="text" value="25BC02JPP3 - QTY 1"/>	
PH: <input style="width: 40px;" type="text" value="3"/>	MAX AMB: <input style="width: 60px;" type="text" value="40 C"/>	ID#: <input style="width: 150px;" type="text"/>	
INSUL CLASS: <input style="width: 40px;" type="text" value="F"/>	Asm. Pos: <input style="width: 150px;" type="text" value="F1"/>	DUTY: <input style="width: 150px;" type="text" value="CONT"/>	
HP: <input style="width: 40px;" type="text" value="1"/> <input style="width: 60px;" type="text"/> RPM: <input style="width: 40px;" type="text" value="1160"/> <input style="width: 60px;" type="text"/>	HP: <input style="width: 40px;" type="text"/> <input style="width: 60px;" type="text"/> RPM: <input style="width: 40px;" type="text"/> <input style="width: 60px;" type="text"/>		
VOLTS: <input style="width: 40px;" type="text" value="460"/> <input style="width: 60px;" type="text"/>	VOLTS: <input style="width: 40px;" type="text"/> <input style="width: 60px;" type="text"/>		
FL AMPS: <input style="width: 40px;" type="text" value="1.8"/> <input style="width: 60px;" type="text"/>	FL AMPS: <input style="width: 40px;" type="text"/> <input style="width: 60px;" type="text"/>		
SF AMPS: <input style="width: 40px;" type="text" value="2.0"/> <input style="width: 60px;" type="text"/>	SF AMPS: <input style="width: 40px;" type="text"/> <input style="width: 60px;" type="text"/>		
SF: <input style="width: 40px;" type="text" value="1.15"/>	DESIGN: <input style="width: 40px;" type="text" value="B"/>	CODE: <input style="width: 40px;" type="text" value="K"/>	
NEMA NOM EFFICIENCY: <input style="width: 40px;" type="text" value="82.5"/>	NOM PF: <input style="width: 40px;" type="text" value="62.1"/>	KiloWatt: <input style="width: 40px;" type="text" value=".7"/>	
GUARANTEED EFFICIENCY: <input style="width: 40px;" type="text" value="80.0"/>	MAX KVAR: <input style="width: 40px;" type="text" value=".9"/>	HZ: <input style="width: 40px;" type="text" value="60"/>	

**HAZARDOUS LOCATION DATA (IF APPLICABLE):**

DIVISION: <input style="width: 100px;" type="text"/>	CLASS I: <input style="width: 100px;" type="text"/>	GROUP I: <input style="width: 100px;" type="text"/>
TEMP CODE: <input style="width: 100px;" type="text"/>	CLASS II: <input style="width: 100px;" type="text"/>	GROUP II: <input style="width: 100px;" type="text"/>

**VFD DATA (IF APPLICABLE):**

VOLTS: <input style="width: 150px;" type="text"/>	
AMPS: <input style="width: 150px;" type="text"/>	
TORQUE 1: <input style="width: 150px;" type="text"/>	TORQUE 2: <input style="width: 150px;" type="text"/>
VFD LOAD TYPE 1: <input style="width: 150px;" type="text"/>	VFD LOAD TYPE 2: <input style="width: 150px;" type="text"/>
VFD HERTZ RANGE 1: <input style="width: 150px;" type="text"/>	VFD HERTZ RANGE 2: <input style="width: 150px;" type="text"/>
VFD SPEED RANGE 1: <input style="width: 150px;" type="text"/>	VFD SPEED RANGE 2: <input style="width: 150px;" type="text"/>
SERVICE FACTOR: <input style="width: 150px;" type="text"/>	FL SLIP: <input style="width: 150px;" type="text"/>
NO. POLES: <input style="width: 60px;" type="text" value="6"/>	MAGNETIZING AMPS: <input style="width: 60px;" type="text" value="1.4"/>
VECTOR MAX RPM: <input style="width: 150px;" type="text"/>	Encoder PPR: <input style="width: 150px;" type="text"/>
Radians / Seconds: <input style="width: 60px;" type="text" value="1"/>	Encoder Volts: <input style="width: 150px;" type="text"/>

**TEAO DATA (IF APPLICABLE):**

HP (AIR OVER): <input style="width: 100px;" type="text"/>	HP (AIR OVER M/S): <input style="width: 100px;" type="text"/>	RPM (AIR OVER): <input style="width: 100px;" type="text"/>	RPM (AIR OVER M/S): <input style="width: 100px;" type="text"/>
FPM AIR VELOCITY: <input style="width: 100px;" type="text"/>	FPM AIR VELOCITY M/S: <input style="width: 100px;" type="text"/>	FPM AIR VELOCITY SEC: <input style="width: 100px;" type="text"/>	

**ADDITIONAL NAMEPLATE DATA:**

Decal / Plate	WD=499495	Customer PN	
Notes		Non Rev Ratchet	
Max Temp Rise	80C RISE/RES@1.00SF	OPP/Upper Oil Cap	GREASE
Thermal (WDG)		SHAFT/Lower Oil Cap	GREASE
Altitude			
Regulatory Notes		Regulatory Compliance	CC 030A
COS		Marine Duty	
Balance	0.05 IN/SEC	Arctic Duty	
3/4 Load Eff.	81.7	Inrush Limit	
Motor Weight (LBS)	70	Direction of Rotation	
Sound Level		Special Note 1	
Vertical Thrust (LBS)		Special Note 2	
Thrust Percentage		Special Note 3	
Bearing Life		Special Note 4	
Starting Method		Special Note 5	
Number of Starts		Special Note 6	
200/208V 60Hz Max Amps		SH Max. Temp.	
190V 50 hz Max Amps		SH Voltage	
380V 50 Hz Max Amps		SH Watts	
NEMA Inertia		Load Inertia	
Sumpheater Voltage		Sumpheater Wattage	
Special Accessory Note 1		Special Accessory Note 16	
Special Accessory Note 2		Special Accessory Note 17	
Special Accessory Note 3		Special Accessory Note 18	
Special Accessory Note 4		Special Accessory Note 19	
Special Accessory Note 5		Special Accessory Note 20	
Special Accessory Note 6		Special Accessory Note 21	
Special Accessory Note 7		Special Accessory Note 22	
Special Accessory Note 8		Special Accessory Note 23	
Special Accessory Note 9		Special Accessory Note 24	
Special Accessory Note 10		Special Accessory Note 25	
Special Accessory Note 11		Special Accessory Note 26	
Special Accessory Note 12		Special Accessory Note 27	
Special Accessory Note 13		Special Accessory Note 28	
Special Accessory Note 14		Special Accessory Note 29	
Special Accessory Note 15		Special Accessory Note 30	

**NIDEC MOTOR CORPORATION  
ST. LOUIS, MO**



TYPICAL NAMEPLATE DATA  
ACTUAL MOTOR NAMEPLATE LAYOUT MAY VARY  
SOME FIELDS MAY BE OMITTED

Nidec trademarks followed by the ® symbol are registered with the U.S. Patent and Trademark Office.

## MOTOR PERFORMANCE

MODEL NO.	CATALOG NO.	PHASE	TYPE	FRAME
BH48	8P1P3C	3	CE	145T

ORDER NO.	17332	LINE NO.

MPI:	67666
HP:	1
POLES:	6
VOLTS:	460
HZ:	60
SERVICE FACTOR:	1.15
EFFICIENCY (%):	
S.F.	82.4
FULL	82.5
3/4	81.7
1/2	78.1
1/4	66.9
POWER FACTOR (%):	
S.F.	66.6
FULL	62.1
3/4	52.5
1/2	40
1/4	24.9
NO LOAD	7.1
LOCKED ROTOR	59.7
AMPS:	
S.F.	2
FULL	1.8
3/4	1.6
1/2	1.5
1/4	1.4
NO LOAD	1.4
LOCKED ROTOR	10.9
NEMA CODE LETTER	K
NEMA DESIGN LETTER	B
FULL LOAD RPM	1160
NEMA NOMINAL EFFICIENCY (%)	81.5
GUARANTEED EFFICIENCY (%)	78.5
MAX KVAR	0.9
AMBIENT (°C)	40
ALTITUDE (FASL)	3300
SAFE STALL TIME-HOT (SEC)	30
SOUND PRESSURE (DBA @ 1M)	51
TORQUES:	
BREAKDOWN{% F.L.}	399
LOCKED ROTOR{% F.L.}	300
FULL LOAD{LB-FT}	4.5

NEMA Nominal and Guaranteed Efficiencies are up to 3,300 feet above sea level and 25 ° C ambient

The Above Data Is Typical, Sinewave Power Unless Noted Otherwise

**NIDEC MOTOR CORPORATION**  
ST. LOUIS, MO



Nidec trademarks followed by the ® symbol are registered with the U.S. Patent and Trademark Office.



499495

### Motor Wiring Diagram

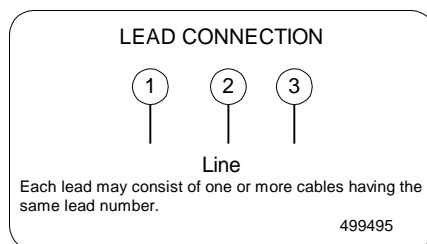
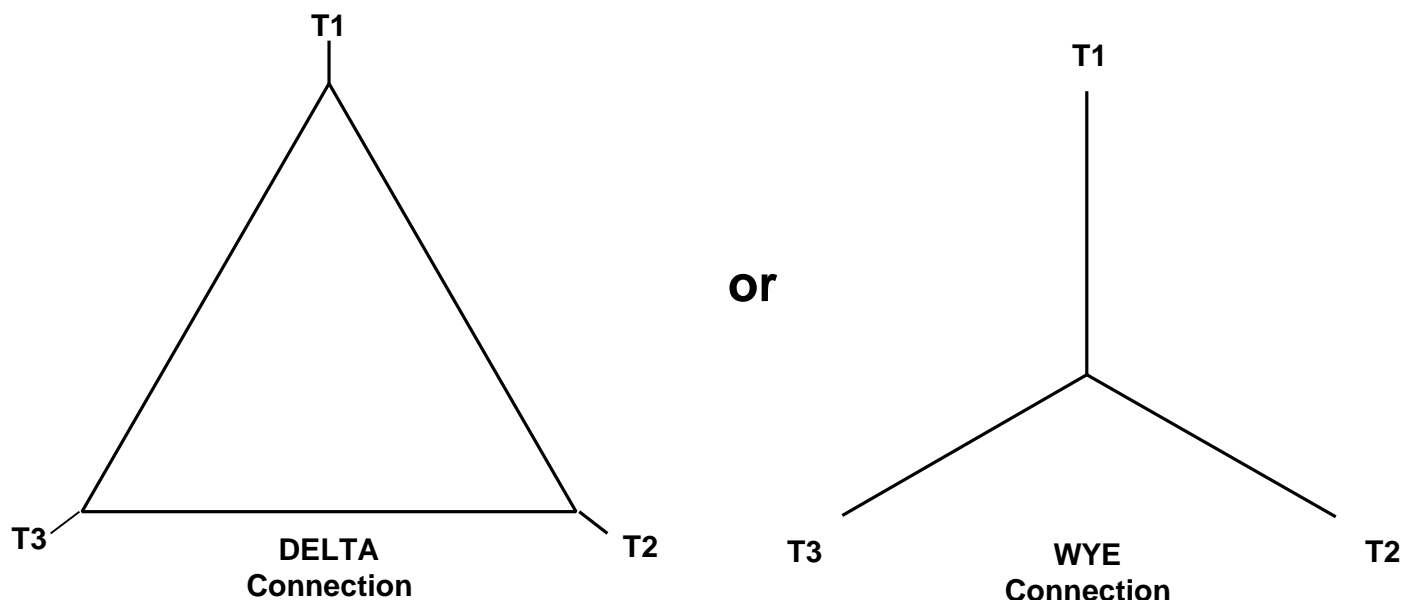

To reverse direction of rotation interchange connections L1 and L2.

Each lead may be comprised of one or more cables.  
Each cable will be marked with the appropriate lead number.

## RENEWAL PARTS

### 56 thru 145 - TOTALLY ENCLOSED MOTORS

Types: CE, CEF, CEF4, CT, CT4, CTC, CTE, CTE4, CTEF, CTF, CTF1, CTFNI, CTI, CTN, FCT, FCTF, FTC, FTFC, J, JCE, JF, JFC, JFN, JFNC, JFNI, JN, JV, TC, TC1, TC4, TCE, TCEF, TCEN, TCE1, TCF, TCF1, TCF4, TCFI, TCI, TCN, TF, TFN, TFNI, TM, TMF, TMQ

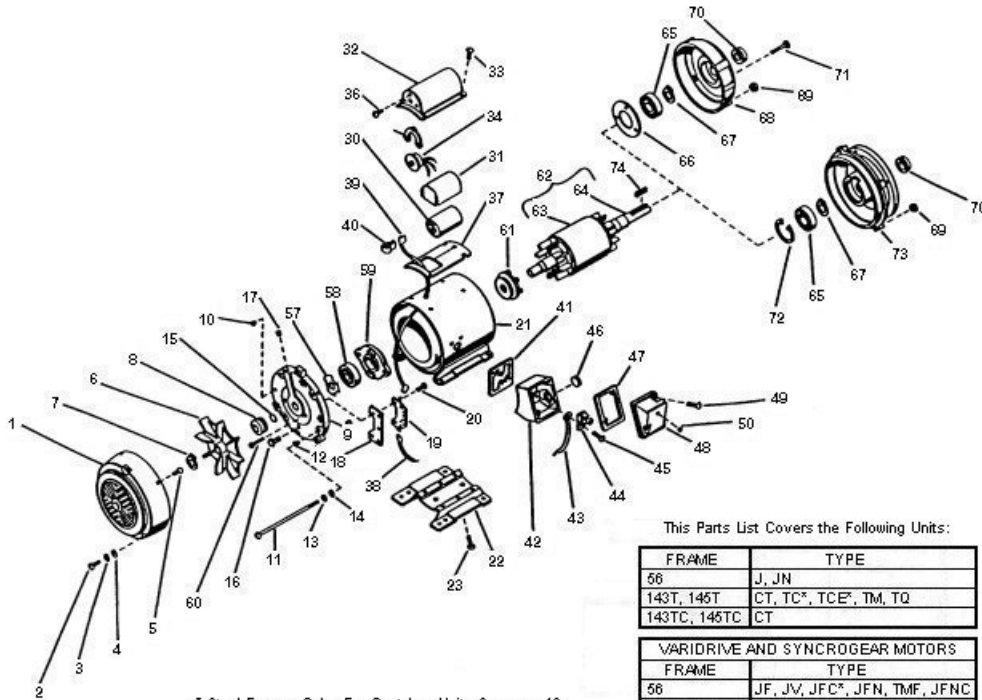

This Parts List Covers the Following Units:

FRAME	TYPE
56	J, JN
143T, 145T	CT, TC*, TCE*, TM, TQ
143TC, 145TC	CT

VARIDRIVE AND SYNCROGEAR MOTORS	
FRAME	TYPE
56	JF, JV, JFC*, JFN, TMF, JFNC
143T, 145T	TF, TFC, TMF

\* Steel Frames Only. For Cast Iron Units See page 13

ITEM NO.	QTY	NAME OF PART
1	1	Fan Cover Guard (Not used on types JN, JFN & JFNC)
2	3	Self Tapping Screw (Used on frame 56 types J, JF, JFC, TMF & frames 143 & 145T, type TF, TM, TFC, TMF, TMQ) Round Head Machine Screw (Qty 2 frame 56 type J)
3	3	Lockwasher (Used on frame 56 types J, JF, JFC, TMF, and frames 143T & 145T, types TF, TM, TFC, TMF, TMQ) (Qty 2 frame 56 type J)
4	3	Plain Washer (Used on frame 56 types J, JF, JFC and frames 143T & 145T type TFC)
5	4	Hex Head Cap Screw (Types CT, TC, & TCE)
6	1	Fan (Not used on types JN, JFN, & JFNC)

ITEM NO.	QTY	NAME OF PART
7	1	Retaining Snap Ring (Not used on types J, JN, JV, JFN & JFNC)
8	1	Water Deflector (Types JFC & TFC only)
9	1	Bracket
10	4	Plastic Plug (Not used on types CT, JN, TC, JFN, TCE)
11	4	Screw
12	4	Bushing (Not used on types J, JV, CT, JN, TC, JFN, TCE)
13	4	Lockwasher (Used on types J, JN, JV, TMF)
14	4	Plain Washer (Used on type TMF)
15	1	Bracket Plug (Types JN & JFNC)
16	2	Vent Plug (Types TC & TCE)
17	4	Hex Countersunk Pipe Plug (Types TC & TCE)
18	1	Switch Insulator (Types TM, TMF, TMQ)

**WARNING:**

Any disassembly or repair work on explosionproof motors will void the Underwriters Laboratories, Inc. label unless done by the manufacturer, or a facility approved by the Underwriters Laboratories, Inc. Refer to your nearest sales office for assistance.

**BEARINGS:**

Refer to motor nameplate for the bearing numbers.

**PRICES:**

Parts stocking distributors: refer to renewal parts numerical index. All Others: refer to your nearest parts distributor.

reference: Renewal Parts Section 700, Pages 10 & 11



## RENEWAL PARTS

56 thru 145 - TOTALLY ENCLOSED MOTORS

Types: CE, CEF, CEF4, CT, CT4, CTC, CTE, CTE4, CTEF, CTF, CTFI, CTFNI, CTI, CTN, FCT, FCTF, FTC, FTFC, J, JCE, JF, JFC, JFN, JFNC, JFNI, JN, JV, TC, TC1, TC4, TCE, TCEF, TCEN, TCE1, TCF, TCF1, TCF4, TCFI, TCI, TCN, TF, TFN, TFNI, TM, TMF, TMQ

ITEM NO.	QTY	NAME OF PART
19	1	Starting Switch Assembly (Types TM, TMF, TMQ)
20	3	Self Tapping Screw (Types TM, TMF, TMQ)
21	1	Wound Stator Assembly (Mounting Base Included on types CT, TC, TCE, TM, TMQ)
22	1	Mounting Bases (Types J & JN)
23	2	Screws (Types J & JN)
24-29	-	Not Used
30	1	Starting Capacitor (Types TM, TMF, TMQ)
31	1	Capacitor Insulator (Types TM, TMF, TMQ)
32	1	Capacitor Box (Types TM, TMF, TMQ)
33	4	Self Tapping Screws (Types TM, TMF, TMQ)
34	1	Thermal Protector (Type TMQ)
35	1	Clamping Plate (Type TMQ)
36	3	Self Tapping Screw (Type TMQ)
37	1	Gasket (Type TMQ)
38	1	Connection Lead Assembly No. 5 (Included with Wound Stator Assembly item 20) (Types TM & TMQ)
39	1	Connection Lead Assembly No. 10 (Included with Wound Stator Assembly item 20) (Types TM & TMQ)
40	4	Sleeving Insulation (Included with Items No. 38 & 39)
41	1	Gasket (Not used on J, JN, JV)
42	1	Outlet Box Base
43	1	Connection Lead Assembly Ground (Type TMQ)
44	1	Grounding Lug (Types TC, TCE)
45	2	Self Tapping Screw (Qty. 4 Round Head Screw on types J, JN, JV)
46	1	Plastic Plug (Types CT, TC, TCE)
47	1	Gasket (Types CT, TC, TCE)

ITEM NO.	QTY	NAME OF PART
48	1	Outlet Box Cover
49	2	Screw (Qty. 4 Round Head Screws on types J, JN, JV)
50	3	Plastic Plug (Types JFC, JFNC, TFC)
51-56	-	Not Used
57	1	Wave Spring Washer (Type CT without "C" Bracket, TC, TCE, TM, TMQ, TMF)
58	1	Ball Bearing
59	1	Bearing Cap (Type JV only)
60	2	Round Head Screw (Type JV only)
61	1	Rotary Actuator (Types TM, TMQ, TMF)
62	1	Rotor Assembly (Includes items 63 & 64)
63	1	Rotor Core
64	1	Rotor Shaft
ITEMS 65 THRU 74 ARE FOR TYPES J, CT, JN, TC, TCE, TM, TMQ		
65	1	Ball Bearing (Refer to section 775)
66	1	Retaining Cap (Type TMQ)
67	1	Retaining Snap Ring (Types CT with "C" Bracket, & TMQ)
68	1	Bracket (Not used with "C" Bracket)
69	4	Hex Nut
70	1	Water Deflector (Types CT with "C" Bracket, TC, TCE)
71	3	Round Head Machine Screw (Type TMQ)
72	1	Retaining Snap Ring (Type CT with "C" Bracket)
73	1	"C" Bracket
74	1	Square Key

**WARNING:**

Any disassembly or repair work on explosionproof motors will void the Underwriters Laboratories, Inc. label unless done by the manufacturer, or a facility approved by the Underwriters Laboratories, Inc. Refer to your nearest sales office for assistance.

**BEARINGS:**

Refer to motor nameplate for the bearing numbers.

**PRICES:**

Parts stocking distributors: refer to renewal parts numerical index. All Others: refer to your nearest parts distributor.

reference: Renewal Parts Section 700, Pages 10 & 11

# Suitability of Integral Horsepower (IHP)\* Motors on Variable Frequency Drives

## Variable Frequency Drives (VFD)

All Nidec Motor Corporation inverter duty motors have 40°C ambient, 1.0 SF on Inverter Power, 3300 ft. max altitude, 460 voltage or less line power, up to 10:1 speed range on Variable Torque and Class F Insulation.

Nidec Motor Corporation's INVERTER GRADE® insulated motors exceeded NEMA® MG-1 Part 30 & 31 before the standards were established.

We are a leader in the development of electric motors to withstand pulse width modulated (PWM) drives evolution from power transistors to higher switching frequency insulated gate bipolar transistors (IGBTs).

Today, as the need for medium duty motor inverter applications grows, Nidec Motor Corporation provides products to meet these demands.

Through continued research and development, Nidec Motor Corporation has included the insulation wire from its INVERTER GRADE® motors in all Premium Efficient motors, enhancing their potential inverter compatibility.

Inverter compatibility with motors is complex. As a result, many variables must be considered when determining the suitability of certain types of motors. These variables include:

- Torque requirements (Constant or Variable)
- Speed Range
- Line/System Voltage
- Cable Length between VFD & Motor
- Drive Switching (Carrier) Frequency Motor Construction
- VFD dv/dt
- High Temperatures High Humidity

Wider speed ranges, higher voltages, higher switching frequencies and increased cable lengths all add to the severity of the application and therefore the potential for premature motor failure. Nidec Motor Corporation has differentiated its products into families for your ease of selection for various inverter applications.

## Warranty Guidelines

The information within this section refers to the motor and drive application guidelines and limitations for warranty.

## Hazardous Location Motors

Use of a variable frequency drive with the motors in this catalog, intended for use in hazardous locations, is only approved for Division 1, Class I, Group D hazardous location motors with a T2B temperature code, with a limitation of 2:1 constant torque or 10:1 variable torque output. No other stock hazardous location motors are inherently suitable for operation with a variable frequency drive. If other requirements are needed, including non-listed Division 2, please contact your Nidec Motor Corporation territory manager to conduct an engineering inquiry.

## 575 Volt Motors

575 volt motors can be applied on inverters when output filters are used.

## Applying INVERTER GRADE® Insulated Motors on Variable Frequency Drives (2, 4, 6 pole)

The products within this catalog labeled "Inverter Duty" or "Vector Duty" are considered INVERTER GRADE® insulated motors. INVERTER GRADE® motors exceed the NEMA® MG-1 Part 31 standard.

Nidec Motor Corporation provides a three-year limited warranty on all NEMA® frame INVERTER GRADE® insulated motors and allows long cable runs between the motor and the VFD (limited to 400 feet typical without output filters). Cable distance can be further limited by hot and humid environments and VFD manufacturers cable limits. These motors may be appropriate for certain severe inverter application or when the factors relating to the end use application are undefined (such as spares).

Nidec Motor Corporation's U.S. Motors® brand is available in the following INVERTER GRADE® insulated motors:

- Inverter Duty NEMA® frame motors good for 10:1 Variable Torque & 5:1 Constant Torque, including Vertical Type RUSI
- Inverter Duty motors rated for 10:1 Constant Torque
- ACCU-Torc® and Vector Duty Motors with full torque to 0 Speed
- 841 Plus® NEMA® Frame Motors

## Applying motors that do not have INVERTER GRADE® insulation on Variable Frequency Drives (2, 4, 6 pole)

Meet NEMA® MG-1, Section IV, Part 31.4.4.2. They can be used with adjustable frequency drives under the following parameters: On NEMA® frame motors, 10:1 speed rating on variable torque loads & 4:1 speed range on constant torque loads. On TITAN® frame motors, 10:1 speed rating on variable torque loads. On TITAN® frame motors, inquiry required for suitability on constant torque loads. Cable distances are for reference only and can be further limited by hot and humid environments. Refer to specific VFD manufacturers cable limits.

Cable Distances			
Maximum Cable Distance VFD to Motor			
Switching Frequency	460 Volt	230 Volt	380 Volt
3 KHz	127 ft	400 ft	218 ft
6 KHz	90 ft	307 ft	154 ft
9 KHz	73 ft	251 ft	126 ft
12 KHz	64 ft	217 ft	109 ft
15 KHz	57 ft	194 ft	98 ft
20 KHz	49 ft	168 ft	85 ft

**Applying Standard & Energy Efficient Motors on Variable Frequency Drives is not recommended. VFD related failures on standard and energy efficient motors 444 frame and above will not be covered under warranty.**

\*This information applies only to Integral Horsepower (IHP) motors as defined on the Agency Approval page, under UL® & CSA® listings where indicated.

† All marks shown within this document are properties of their respective owners.



# Motor / Inverter Compatibility

---

## Thermal Overloads and Single Phase Motors

Motors with thermal overloads installed may not operate properly on a VFD. The current carrying thermal overload is designed for sine wave power. Operation on a VFD may cause nuisance tripping or potentially not protect the motor as would be expected on line power. Thermo-stats or thermistors installed in the motor and connected properly to the VFD may provide suitable thermal overload protection when operating on a VFD. (Consult Codes)

Single phase motors and other fractional horsepower ratings are not designed to be operated on a VFD. Within Nidec Motor Corporation standard products, all motors NEMA<sup>®†</sup> 48 frame (5.5" diameter) and smaller are not suitable for VFD applications. Three phase 56 and 143/145 frame applications should be noted on the catalog price page; or if in doubt ask an Nidec Motor Corporation technical representative for recommendations on compatibility with a VFD.

## Slow Speed Motors

Motors with a base design of slower than six poles require special consideration regarding VFD sizing and minimizing harmonic distortion created at the motor terminals due to cable installation characteristics. Additional external PWM waveform filters and shielded motor cables designed for PWM power may be required to provide acceptable motor life. Harmonic distortion on the output waveform should be kept to a minimum level (less than 10%).

## 690V Applications

Motors that will be applied to 690VAC PWM VFDs require the use of an external filter to limit peak voltage spikes and the use of an INVERTER GRADE<sup>®</sup> motor. Where available, an alternative to using an output filter is to upgrade to a 2300V insulation system.

## Low Voltage TITAN<sup>®</sup> Motors

When using 449 frame and larger motors on PWM type VFDs consider the use of an external filter and shielded motor cables designed for PWM power to minimize harmonic distortion and peak voltages at the motor terminals. Harmonic distortion on the output waveform should be kept to a minimum level (less than 10%).

## Bearing Currents related to PWM waveform

Due to the uniqueness of this condition occurring in the field, protection of the motor bearings from shaft currents caused by common mode voltages is not a standard feature on sine wave or Inverter Duty motor products, unless explicitly noted. Some installations may be prone to a voltage discharge condition through the motor bearings called fluting.

Fluting damage is related to characteristics of the PWM waveform, VFD programming and characteristics and installation.

Bearing fluting as a result of VFD waveform characteristics may be prevented by the installation of a shaft grounding device such as a brush or ring and/or correction of the installation characteristics causing the shaft voltage condition. Insulated bearing(s) may be required. VFD filters may be needed if bearing fluting is to be avoided.

## Multiple Motors on a Single VFD

Special considerations are required when multiple motors are powered from a single VFD unit. Most VFD manufacturers can provide guidelines for proper motor thermal considerations and starting/stopping of motors. Cable runs from the VFD and each motor can create conditions that will cause extra stress on the motor winding. Filters may be required at the motor to provide maximum motor life.

## Grounding and Cable Installation Guidelines

Proper output winding and grounding practices can be instrumental in minimizing motor related failures caused by PWM waveform characteristics and installation factors. VFD manufacturers typically provide detailed guidelines on the proper grounding of the motor to the VFD and output cable routing. Cabling manufacturers provide recommended cable types for PWM installations and critical information concerning output wiring impedance and capacitance to ground.

## Vertical Motors on VFDs

Vertical motors operated on VFD power present unique conditions that may require consideration by the user or installation engineer:

- Non-reversing-ratchet operation can interfere at low speeds (up to 300 RPM) causing locked rotor and drive tripping.
- Unexpected / unacceptable system vibration and or noise levels caused by the torque pulsation characteristics of the PWM waveform, a system critical frequency falling inside the variable speed range of the process or the added harmonic content of the PWM waveform exciting a system component
- Application related problems related to the controlled acceleration/ deceleration and torque of the motor on VFD power and the building of system pressure/ load.
- The impact the reduction of pump speed has on the down thrust reflected to the pump motor and any minimum thrust requirements of the motor bearings
- Water hammer during shutdown damaging the non-reversing ratchet

## Humidity and Non-operational Conditions

The possible build-up of condensation inside the motor due to storage in an uncontrolled environment or non-operational periods in an installation, can lead to an increased rate of premature winding or bearing failures when combined with the stresses associated with PWM waveform characteristics. Moisture and condensation in and on the motor winding over time can provide tracking paths to ground, lower the Megohm resistance of the motor winding to ground, and lower the Corona Inception Voltage level of the winding.

Proper storage and maintenance guidelines are important to minimize the potential of premature failures. Space heaters or trickle voltage heating methods are the preferred methods for drying out a winding that has low megaohm readings. Damage caused by these factors are not covered by the limited warranty provided unless appropriate heating methods are properly utilized during non-operational periods and prior to motor start-up.

**NEMA<sup>®†</sup> Application Guide for AC Adjustable Speed Drive  
Systems: <http://www.nema.org/stds/acadjustable.cfm#download>**

\*This information applies only to Integral Horsepower (IHP) motors as defined on the Agency Approval page, under UL<sup>®†</sup> & CSA<sup>®†</sup> listings where indicated.

† All marks shown within this document are properties of their respective owners.

